

Installation Guide

HempBLOCK RANGE

SOLID VENEER HEMPCRETE BLOCKS



- ✓ CONSTRUCTION
- ✓ SLAB INSULATION
- ✓ PARTITION WALLS
- ✓ INTERNAL THERMAL INSULATION
- ✓ EXTERNAL THERMAL INSULATION



HEMPBLOCK
SOUTH AFRICA

www.hempblockrsa.com

2	The HempBLOCK Collection
3	Why Choose HempBLOCKS?
4	General Product Information
5	HempBLOCK Range
7	HempBLOCKS as Floor Insulation
8	Cutting and Fitting
8	Chasing for Services
9	Exterior and Interior Finishes
10	Fixing Loads
11	Interior Insulation:
11	11 Placement
12	12 Fixings
13	13 Openings
14	Exterior Insulation:
14	14 Preparation
15	15 Laying
16	16 Openings
17	17 Junctions
18	Floor Insulation - Technique
19	Building Partition Walls
20	Door and Window Frames

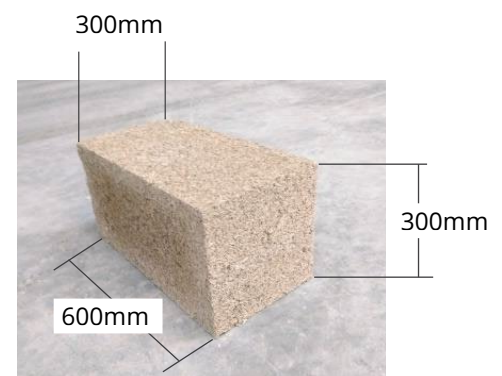
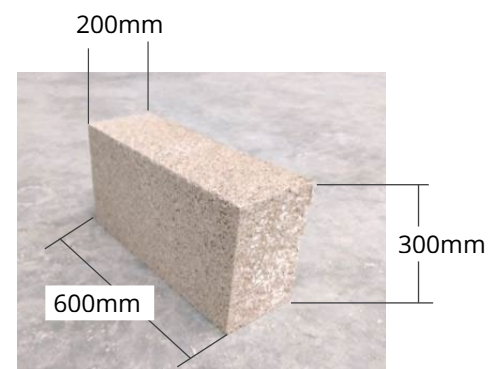
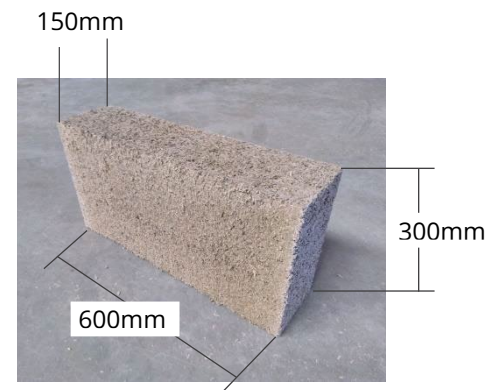
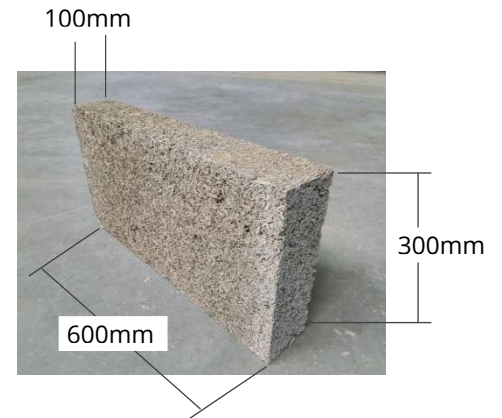

Why choose HempBLOCKS?



PROPERTIES

- Thermally efficient
- Hygroscopic (water-repellent)
- Absorbs sound

SUSTAINABILITY

- 100% natural materials
- Materials are recyclable
- Dried naturally
- Stores CO2

RENOVATION PRODUCT

- Fast and ECONOMICAL
- Reduce heating and cooling costs

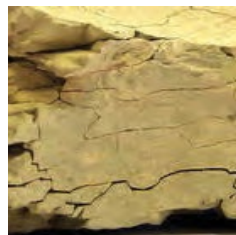

Hemp

Natural Cement
(Lime)

Water



- ✓ Enjoy Comfortable Living Spaces
- ✓ Healthy Environments
- ✓ Energy Savings from reduced heating and cooling requirements

General Product Information

We offer a range of HempBLOCK products that can be used for a range of purposes on the inside and outside of existing or new buildings.

These non-load bearing blocks are primarily used for interior and exterior insulation on existing walls. Our products can also be used to make partition walls with good acoustic values and for insulating flooring. The blocks are laid in a staggered pattern much the same way as concrete blocks and clay bricks and only require a thin layer of HempBLOCK mortar used for jointing purposes.

Blocks can be used as interior insulation and for partition walls. HempBLOCK 100 and 150 offer high performance when space is at a premium.

The thicker HempBLOCK products such as the HempBLOCK 200 and 300 can be used on the exterior of buildings to achieve high levels of thermal insulation. The HempBlock 150 can also be used as exterior insulation. Essentially, block thickness affects insulation values.

Exterior walls are rendered with approved lime renders. Interior walls can be treated similarly or a range of other finishes can be applied depending on the purpose or individual taste.

HempBLOCK Factory



The industrial processes at the HempBLOCK manufacturing facility are specifically designed for the production of hempcrete blocks. Annually the factory produces more than 600,000 blocks.

Each stage of production is rigorously controlled to ensure high quality standards are achieved including the dimensional precision of each block.

HempBLOCK Australia are the exclusive distributors of BIOSYS and MULTICHANVRE blocks, re-branded as HempBLOCK in the UK, USA, Canada, Australia, New Zealand and South Africa.

HEMPBLOCK 100



Suitable for interior insulation or for erecting thin partition walls.

MAXIMUM HEIGHTS* :

- Partition walls : 3m
- Ext & Int. insulation: 3m

Dimensions (mm)	L 600 x W 100 x H 300
Weight	6.5 kg
R-value/m ² .K.W-1 (λ sec)	R 1.5
Phase shift	6.1 h
Blocks per pallet	80 blocks
ft ² of wall per pallet	14.55 m ²
Mortar consumption (Indicative)	5.5 kg / m ²
Fire resistance	FRL 30/30/30

HEMPBLOCK 150



Usable interior as well as exterior and in fill in new constructions

MAXIMUM HEIGHTS* :

- Partition walls : 3m
- Ext & Int. insulation: 4m

Dimensions (mm)	L 600 x W 150 x H 300
Weight	10 kg
R-value/m ² .K.W-1 (λ sec)	R 2.3
Phase shift	9.25 h
Blocks per pallet	56 blocks
ft ² of wall per pallet	10.18 m ²
Mortar consumption (Indicative)	7.5 kg / m ²
Fire resistance	FRL 30/30/30

* For higher walls than those recommended above, please consult us.

HEMPBLOCK 200



Suitable for interior insulation or for erecting thin partition walls.

MAXIMUM HEIGHTS* :

- Partition walls : 3m
- Ext & Int. insulation: 4.5m

Dimensions (mm)	L 600 x W 200 x H 300
Weight	13 kg
R-value/m ² .K.W-1 (λ sec)	R 3
Phase shift	12.3 h
Blocks per pallet	40 blocks
ft ² of wall per pallet	7.27 m ²
Mortar consumption (Indicative)	10 kg / m ²
Fire resistance	FRL 30/30/30

HEMPBLOCK 300



Usable interior as well as exterior and in fill in new constructions

MAXIMUM HEIGHTS* :

- Partition walls : 3m
- Ext & Int. insulation: 5m

Dimensions (mm)	L 600 x W300 x H 300
Weight	21 kg
R-value/m ² .K.W-1 (λ sec)	R 4.6
Phase shift	18.5 h
Blocks per pallet	24 blocks
ft ² of wall per pallet	4.36 m ²
Mortar consumption (Indicative)	16 kg / m ²
Fire resistance	FRL 30/30/30

* For higher walls than those recommended above, please consult us.

NOTE: Please consult your certifier and local building standard/codes prior to the use of this hempcrete block as a floor insulation. We highly recommend adhering to the following tolerances when using the product as a sub-floor

Horizontal

The maximum height difference allowed is 10mm over 10m in length

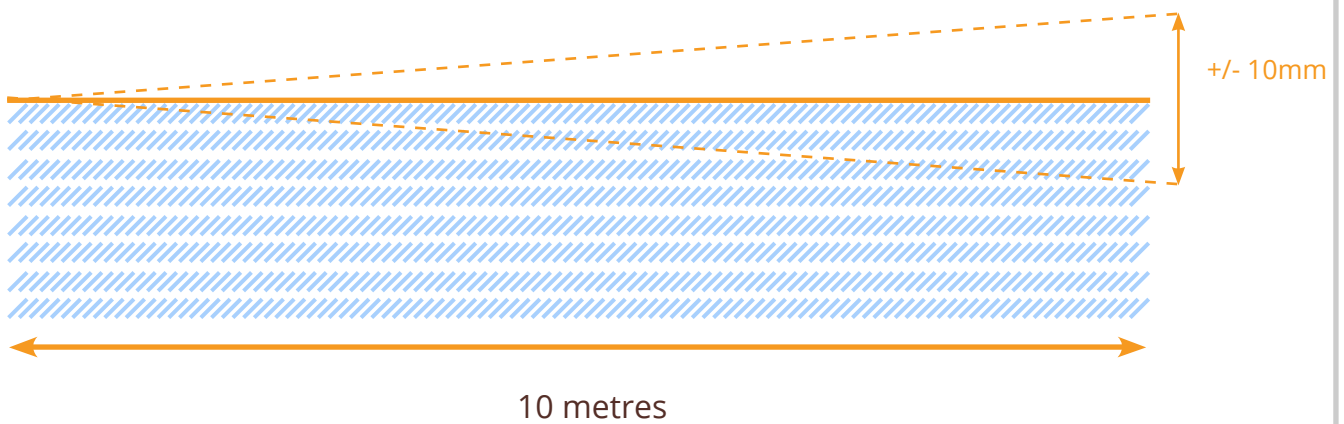

As sub floo

The maximum height difference allowed is 2mm over 1m in length

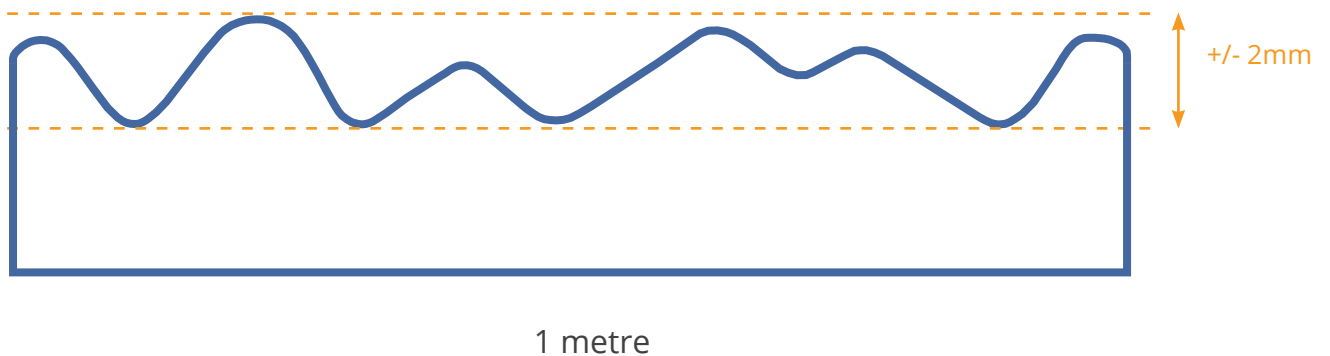

Cutting and Fitting

HempBLOCKS are easily cut with an alligator saw, handsaw, chainsaw or reciprocating saw.

TIP: It may be worth using a band saw for large jobs.



Chasing for Services



The grooves for services such as water, electricity and other cabling are made using an angle grinder, wall chaser or wall slotting machine and suitable hole saws.

After fixing the ducts and boxes, fill grooves with a suitable sealant compatible with the finishing plaster or wall finish

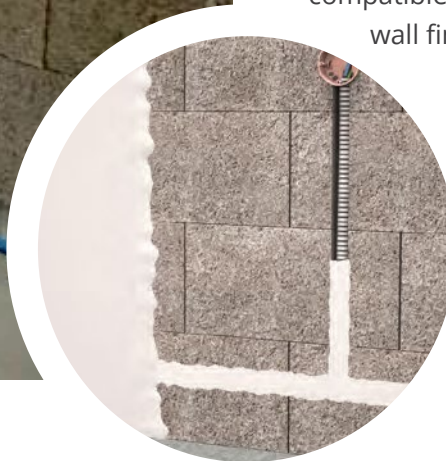

EXTERIOR FINISH

- Lime renders are recommended for exterior finishes
- Fixing mesh to the walls is recommended prior to applying the final finish
- Apply renders in accordance with the manufacturer's instructions.
- A breathable sealer is available.
- See our website suitable HBA approved renders.



INTERIOR FINISH

Many interior finishes are compatible with the HBA BLOCKS.

Among them are:

- Lime render,
- Clay based,
- Earth-based renders, and plaster board.

LIGHT LOADS (up to 10 kg per attachment)

The light load fixing is done with screws 6 x 100mm Zinc wood screws without pilot hole. For optimal fixing, we recommend a zinc bungle or batten screw or a plastic plug such as the Ramset RamPlug with wood screws after drilling of a pilot hole wood drill with 3 points.

HEAVY LOADS (up to 100 kg per attachment)

The fixing of heavy loads is done by using chemical anchors or fixing through the surface with rods and a plate.

CHEMSET METHOD

- Drill a 20mm hole
- Blow out the dust
- Inject the compound
- Introduce the threaded rod
- Let dry

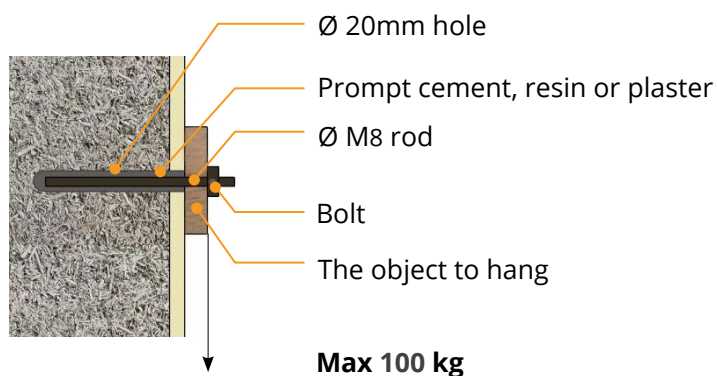

THROUGH FIXATION METHOD

- Drill the hole
- Insert the threaded rod
- Rebate sufficient room for t backing plate to sit flush with th surface to distribute the load

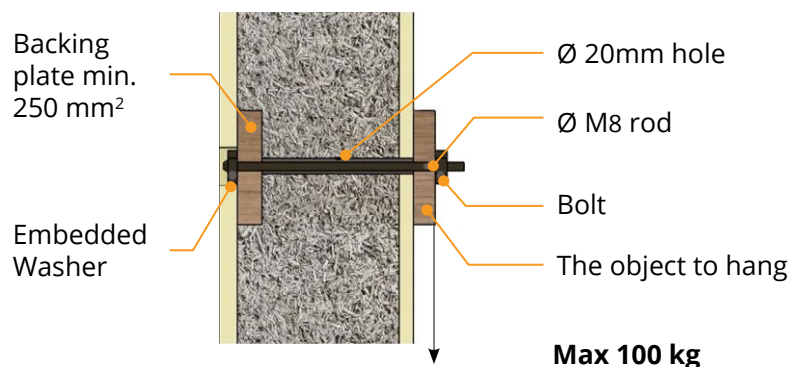

PLACING THE FIRST ROW

The first row must be laid on a bed of PROPRIETARY mortar to avoid rise of moisture.

In order to guarantee plumb and level of the blocks, apply a bed of PROPRIETARY mortar with a thickness of 10 to 20mm to allow adjustment.

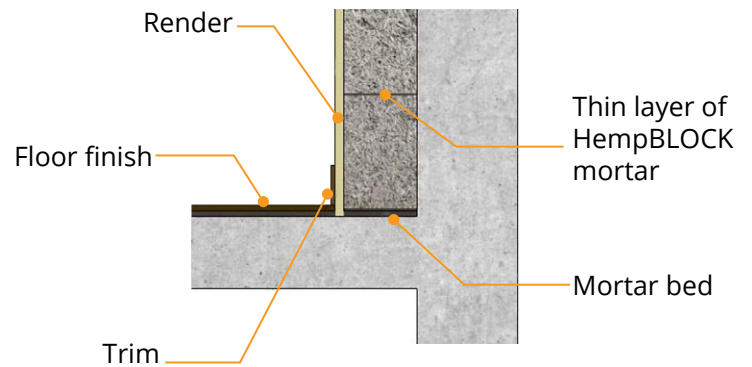

PLACING THE FOLLOWING ROWS

Prepare the mortar and apply it with a notched trowel to the vertical and horizontal faces of the blocks.

CAVITY

There is no need to leave a cavity between the existing wall and the hemp blocks. When the wall to be insulated is not plumb, it is possible to correct this with hempcrete blocks.

If a void appears, fill it with a loose hempcrete mix

JUNCTION WITH THE CEILING

Use fresh hempcrete to fill the space between the last block and the ceiling.

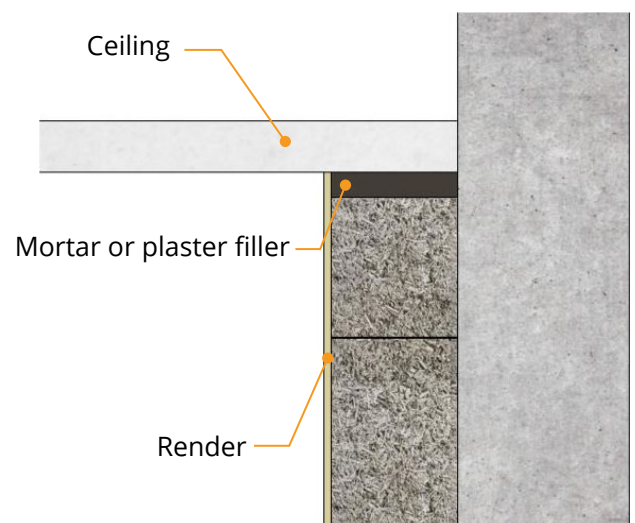

FIXING BETWEEN THE BLOCKS AND AN EXISTING WALL

Just like standard brick veneer techniques it is necessary to fix the hempcrete blocks to an existing wall. Different solutions are possible

WALL TIES

- L tie
- Fix in the existing wall at the height of the joints between the hempcrete blocks
- Embed in the mortar



5 fixations per m

FRAME TIES

- Connections fixed on the side of the hempcrete blocks by galvanized point
- Use a suitable fixing on the existing wall side

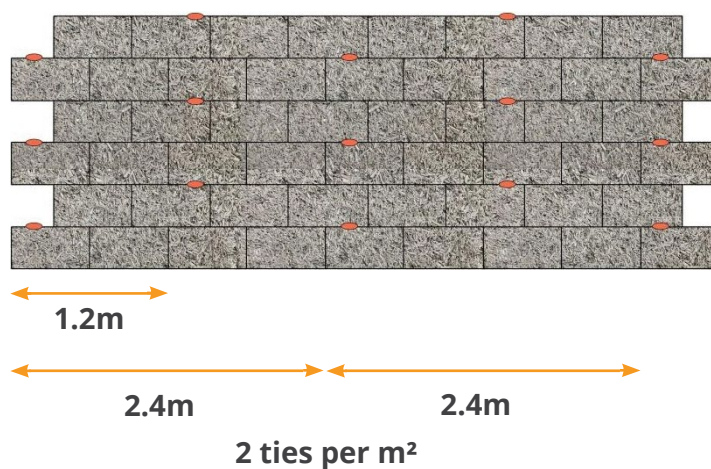

OPENINGS

LINTEL BRACKETS

- Allows to fix blocks above an opening
- Fixing on the load-bearing wall using 3 screws diameter 8mm - minimum
- Choose a bracket adapted to the thickness of the block
- Position a bracket every 600mm
- Place a bracket on both sides of the opening
- It is necessary to mechanically fix the blocks to the 2 brackets

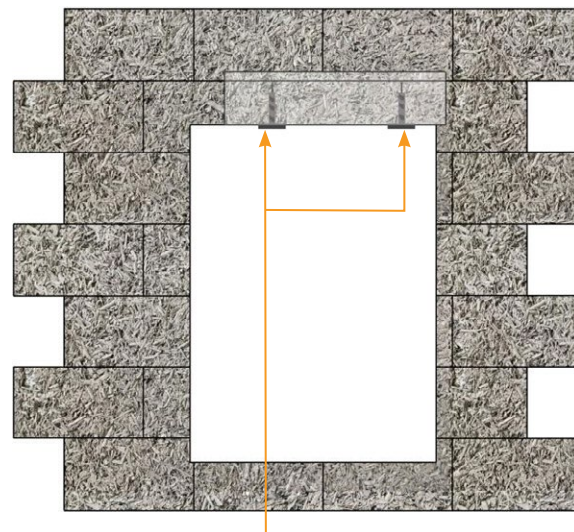

Lintel brackets and a lintel embedded in the render

WITH A WOODEN FRAME

- Installation of a wooden frame around the edge of the opening
- The frame is fixed to the existing wall using connecting brackets

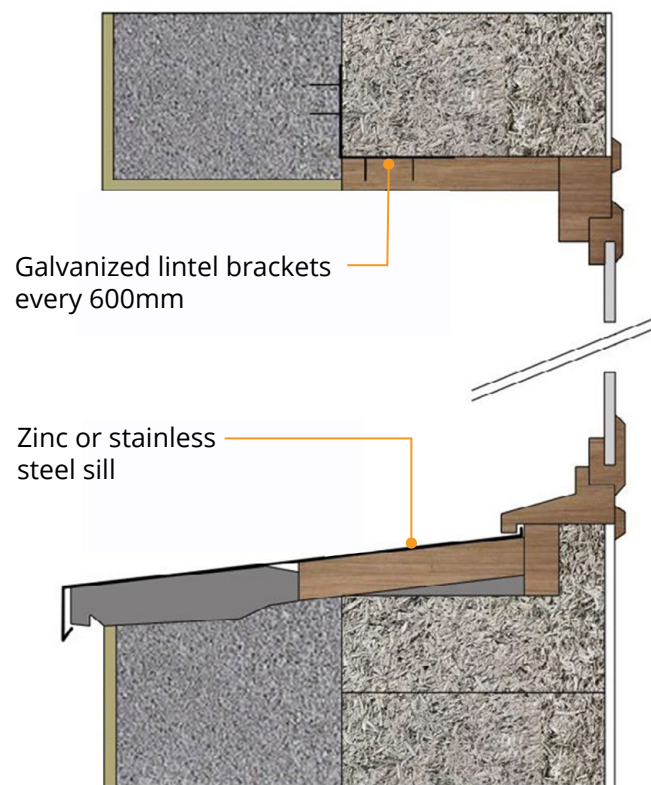

With a manufactured frame

HORIZONTAL INSULATION FLOOR INSULATION

See details on previous pages

SUPPORT

There are 2 solutions :

- Pour a concrete strip footing for the new wall
- Use ready made concrete strip footing blocks

1) CONCRETE FOOTINGS

The footing must be in line with the existing wall or foundation. It is optional to install insulation to avoid a thermal bridging. The 1st row needs to be at least 150mm above FGL (finished ground level).

Install damp course to prevent capillary rising in addition to a water repellent mortar.

Depending on the system of choice, termite proofing should be installed at this stage

PLACING THE FIRST ROW

Lay the first row of HempBLOCKS on a 20mm bed of water-repellent mortar. This thick mortar bed will level in-corrections of the sub foundation.

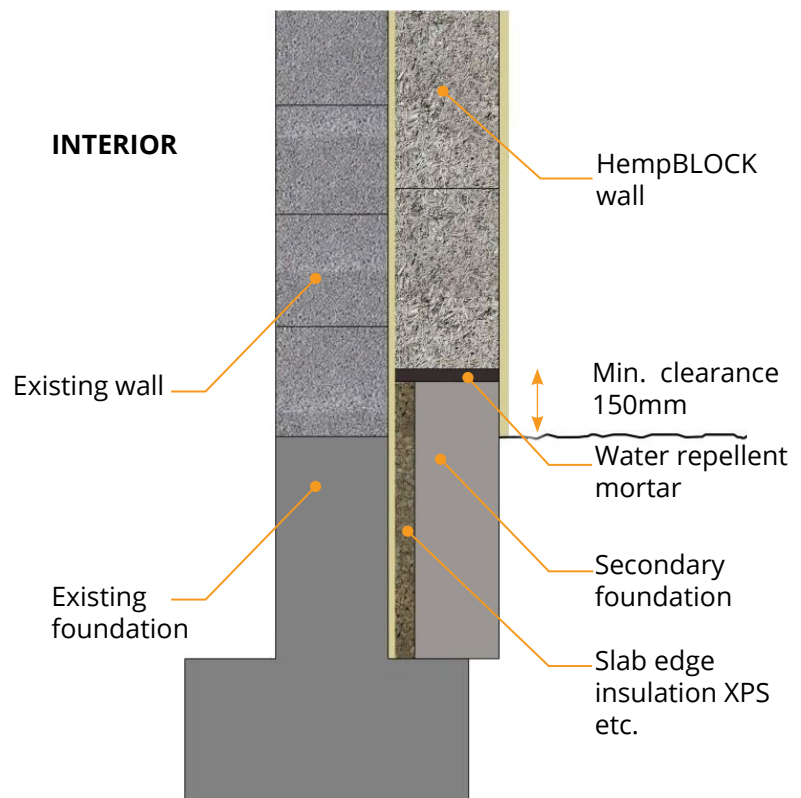

2) THE BASE PROFILE/ANGLE

A base profile can be fixed to the existing wall and serves as a support for the 1st row. Make sure to place it at least 150mm from the FGL.

LAYING THE FIRST ROW

Spread the glue directly on the base profile then place the block. Adjust to plumb and its alignment and repeat for the following blocks.

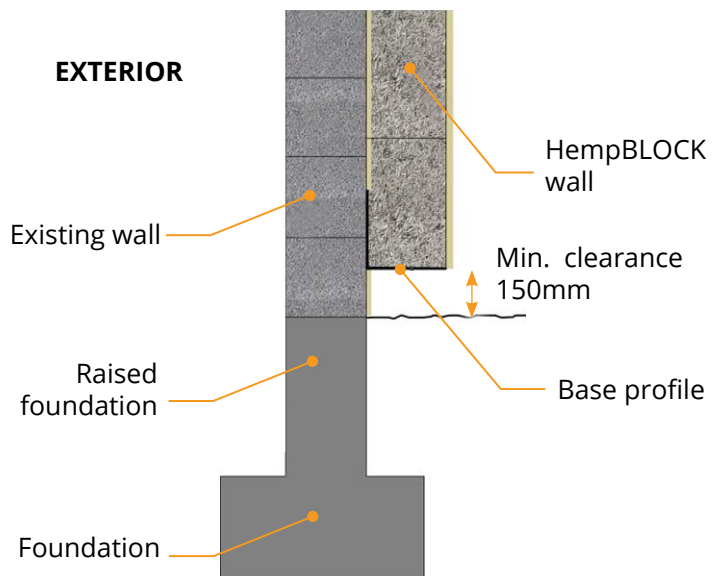

FOLLOWING ROWS

Spread the HempBLOCK mortar using a suitable notched trowel on the vertical and horizontal faces of the blocks already in place.

The use of the notched trowel makes it possible to make thin joints of approximately 3mm. Lay the blocks with staggered joints, with an overlap of at least a third of the length of the blocks, 200 to 400mm.



INSTALLATION OF OPENINGS

TIMBER WINDOW FRAMES

Timber window frames are attached to the existing walls around the perimeter of the openings using galvanized steel brackets.

They will be hidden once the walls are rendered. Hinges of shutters can be fixed on the timber frame.

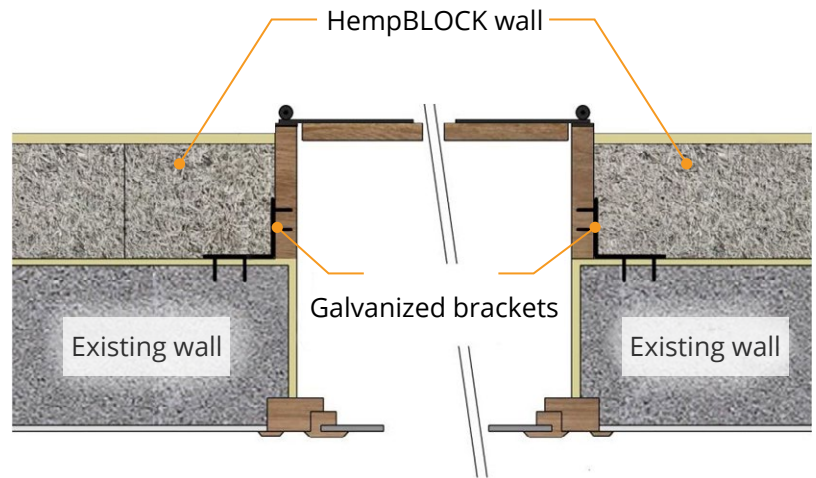

INSTALLATION OF A WINDOW:

The wooden window sill can be replaced by a hempcrete trim. Use a concrete sill or zinc, stainless steel, aluminum, etc. flashing on top of the hempcrete sill trim.

Application of HempBLOCK window sill trim

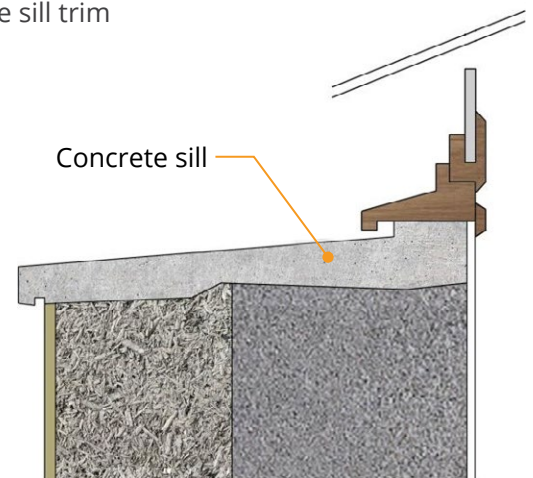

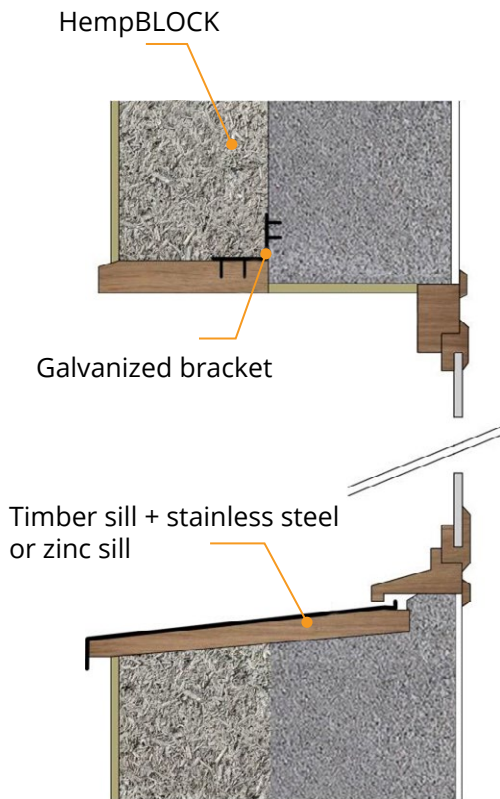

LINTELS

The lintels are supported on each side on the vertical uprights of the frame and are fixed by brackets to the existing wall every 600mm.

ROOF JUNCTION

The HempBLOCK insulation follows the existing wall and continues between the rafters.

If the roof overhang does not protect the top of the blocks and the render from the rain, a zinc flashing should be installed

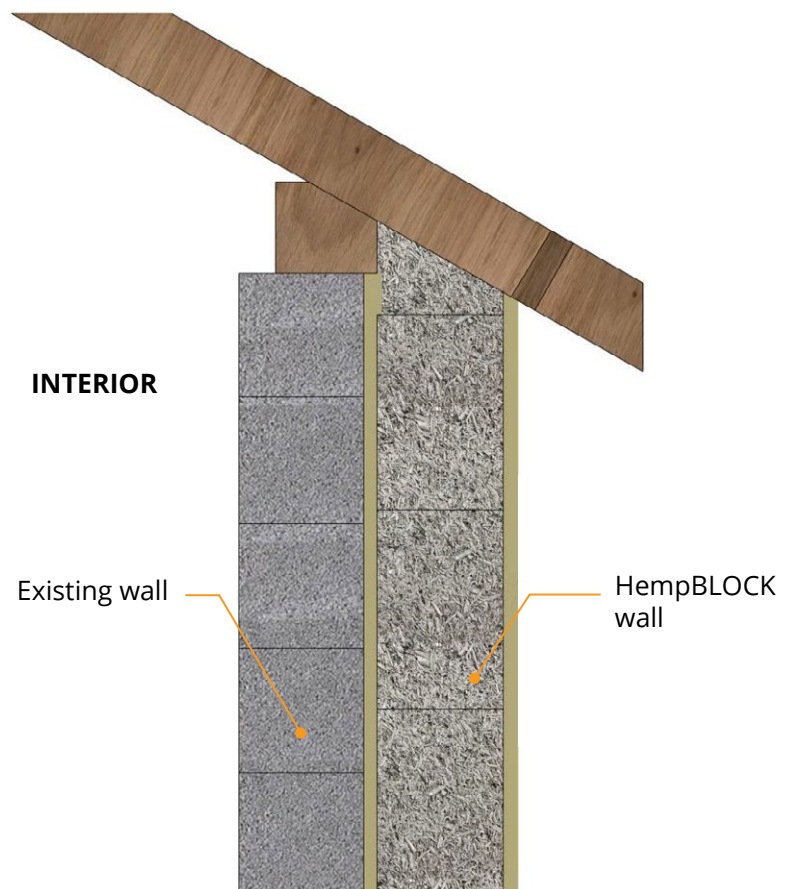

INSTALLATION

It is quick and easy to insulate the floor with HempBLOCKS.

On a slab on solid ground or on a joist-slab floor, water-proofing of the foundation needs to be assured

Place the blocks directly against each other and then cover them either with a screed* (with or without heated floor) or a floor on a joist system

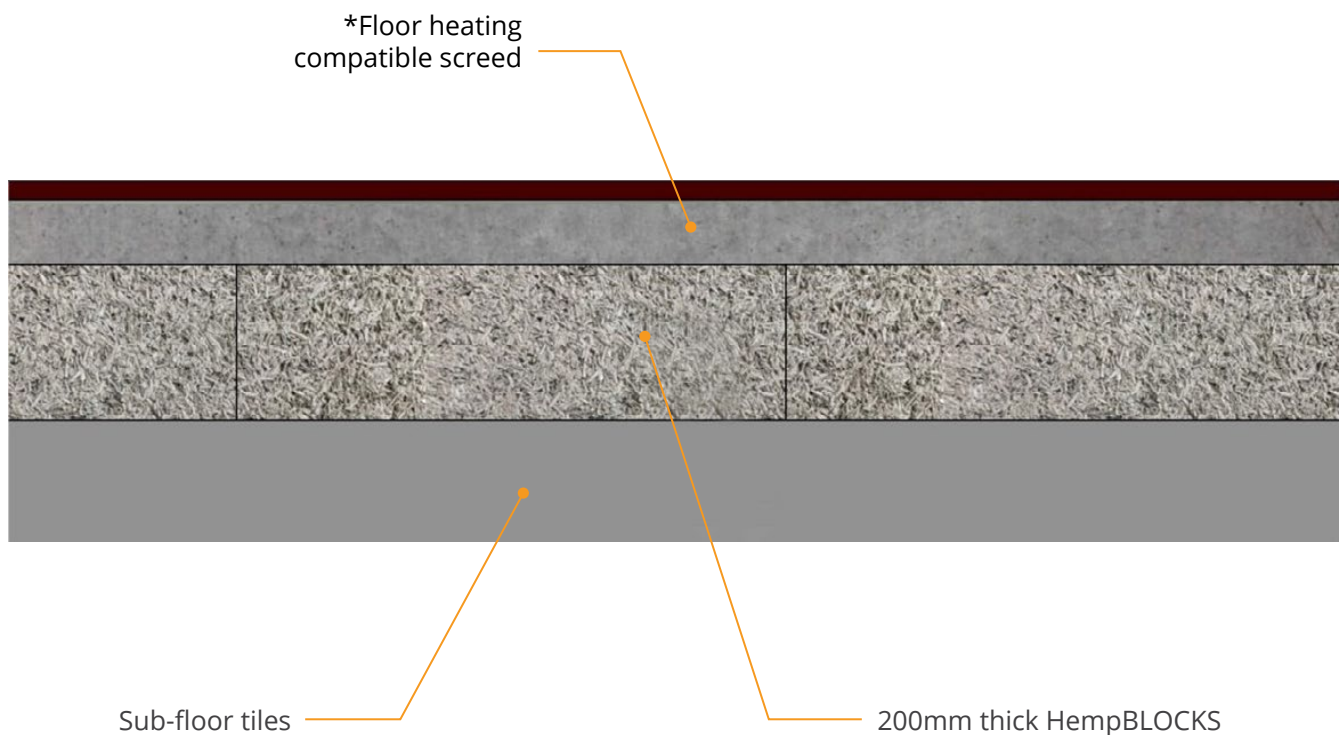

INSTALLATION

The first row of HempBLOCK will be laid on a bed of mortar on the floor

Depending on the nature of the floor, if it is too smooth, it should be roughened up to ensure the adhesion of the HempBLOCK mortar.

CEILING JUNCTION

Connection brackets every 600 mm will connect the last row of blocks to the ceiling. The remaining space is filled with a HempBLOCK mortar, plaster, fresh hempcrete, etc

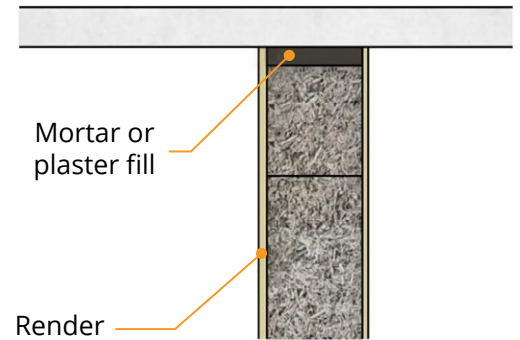
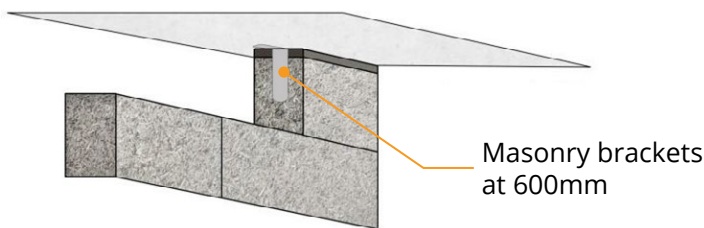

CONNECTION WITH WALLS AND OTHER PARTITIONS

The hemp blocks are fixed to the existing walls using connecting brackets.

The junction between two HempBLOCK partitions must be made at the corner by overlapping the blocks.

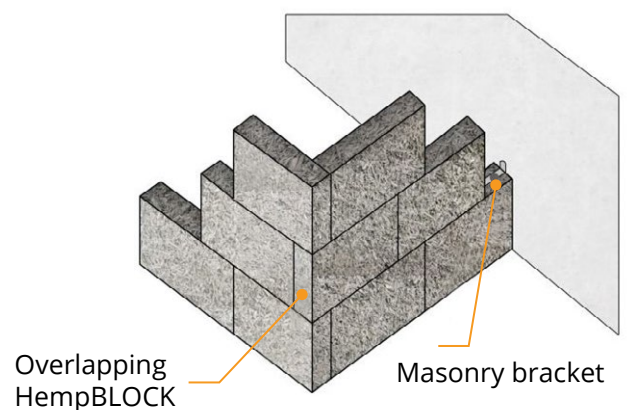

DOOR FRAME INSTALLATION AFTER WALL ERECTION

In order to insert the door later, an opening is reserved in the partition wall to the dimensions provided by the door manufacturer.

Make sure that the final cladding thickness of the partition wall is allowed for (see data from the door manufacturer).

Fill the space between the partition, the frame and the cladding with hempcrete in order to improve the acoustic performance.

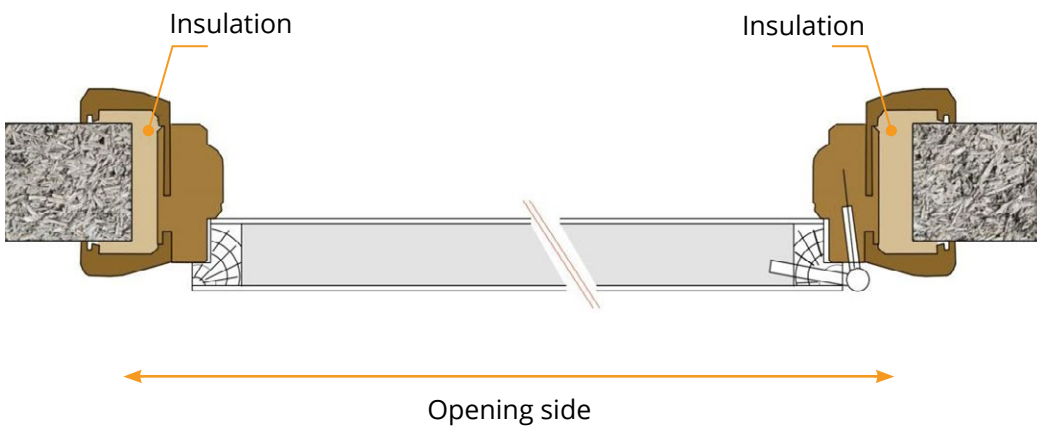

Beware of securing blocks above the opening (propped, with a lintel plus a board to keep the blocks above in line with the rest of the wall).

DOOR FRAME INSTALLATION BEFORE PARTITION WALL ERECTION

Timber window frames are attached to the frame when it is fixed to the floor. On the top, temporary supports need to keep the frame in place.

Attach the blocks to the frame with fixing brackets at each row.

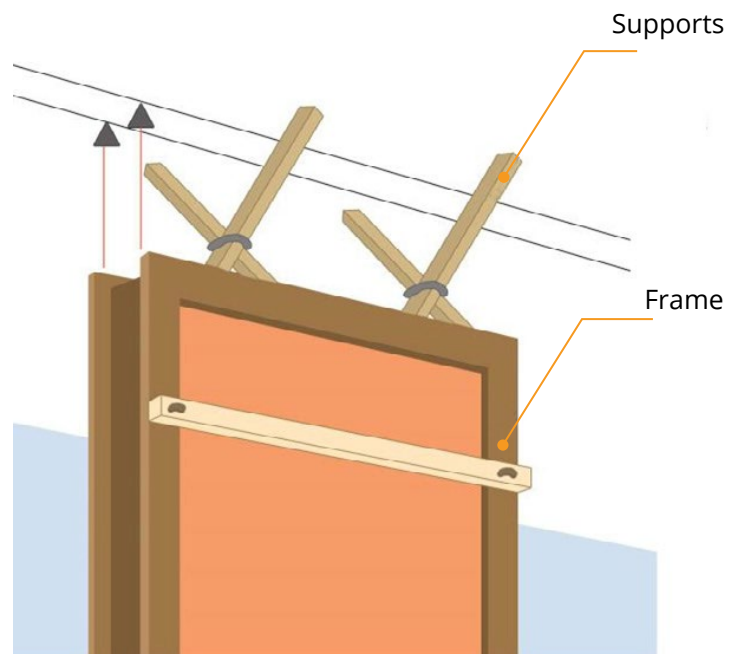

STANDARD WOODEN DOOR FRAME

Screw 2 vertical boards and 1 horizontal board to form a frame.

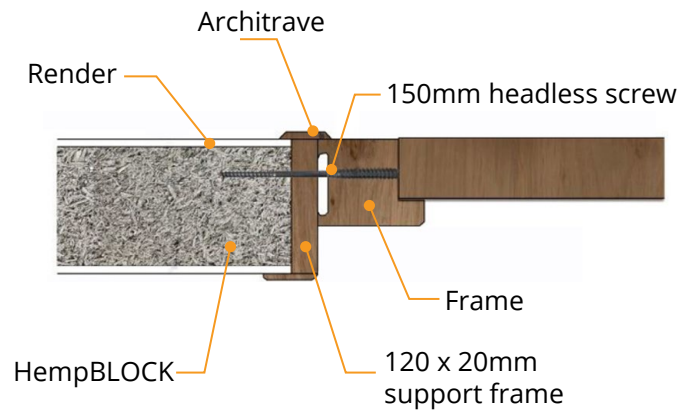

STANDARD DOOR FRAME

Affix the frame aligned to one of the side of the partition wall. When finishing on the aligned side install an architrave.

On the other side, create an external corner with render or plaster and a (quad) beading.

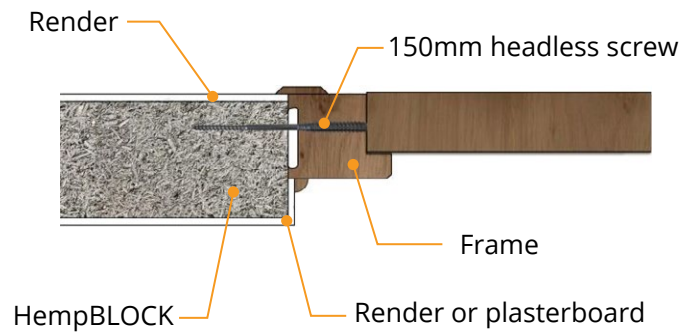

STANDARD DOOR UNIT ADAPTED TO THE WIDTH OF THE PARTITION WALL

Depending on the door manufacturers, choose a door whose frame is the same thickness as the partition wall. For example, 100 or 150mm.

The junction between the frame and the wall will be provided by a architrave on each side.

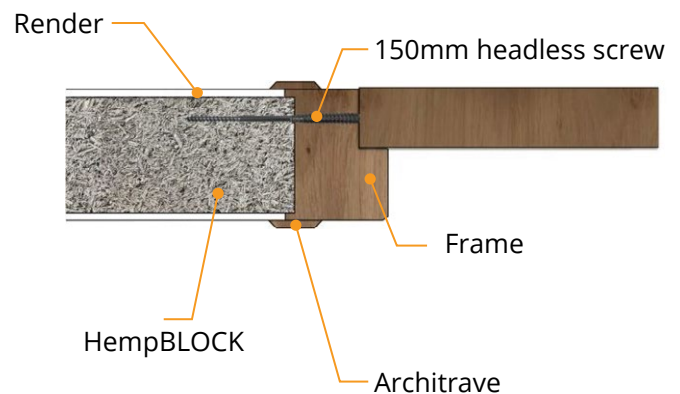



THE HempBLOCK

HempBLOCK Australia is the distributor in USA, Canada, Australia and New Zealand for the BIOSYS system. The factory (shown above) has been built to exclusively manufacture Hempcrete Blocks. The factory guarantees a controlled manufacturing process and a very high quality production of hempcrete blocks. The premises also has an undercover space to allow the blocks to dry naturally.

TECHNICAL SUPPORT

The installation and manufacturers guidelines provided in this document must be used when designing and constructing walls using our HempBLOCKs. While the information provides technical guidance it does not, in any way, replace the need for your design to be certified by a suitably qualified and experienced engineer to ensure it complies with your local building codes and receives the necessary approvals from the relevant authorities prior to commencing any work. Consult us for technical guidance on your construction project.

OUR PARTNERS

+Biosys



VIEILLE
matériaux 

Transforming construction naturally...

CONTACT

admin@hempblockinternational.com